

## BS-2074 Biological Microscope



BS-2074B



BS-2074FB(LED)

### Introduction

BS-2074 series microscopes are high level microscopes which are specially designed for college education, medical and laboratory research. With excellent optical quality, large field of view, excellent objective lens performance, clear and reliable imaging. Ergonomically designed to provide better comfort and experience, focus on the user's operating habits, and constantly optimize the details. The modular design allows for various viewing modes such as brightfield, darkfield, phase contrast, fluorescence and simple polarizing. The intelligent design makes the microscope teaching more flexible and the teaching effect is better. Low maintenance costs and environmentally friendly.

### Features

#### 1. Excellent Optical Design.

- (1) NIS infinite Optical System. NIS infinite plan objectives can provide high contrast and very flat image up to FN22mm, the system always brings you sharp, high resolution and high signal to noise ratio imaging.
- (2) 22mm Wide Field of View. The microscopes achieve the wide field of 22mm view with 10× eyepieces. The eyepiece adopts a flat field distortion-free design to prevent the edge of the field from being imaginary and stray light.

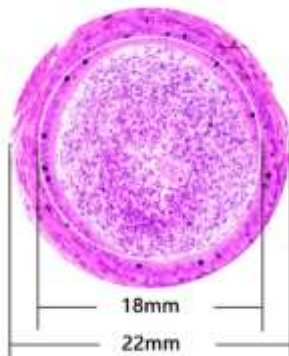

(3) Various Observation methods. Besides bright field observation, dark field, phase contrast, fluorescent and simple polarizing observation methods are optional.

Observation Methods	Bright Field	Dark Field	Phase Contrast	Fluorescent	Simple Polarizing
	●	●	●	●	●

(4) Multifunctional Universal Condenser. BS-2074 series microscopes adopt a universal condenser for bright field, dark field and phase contrast. The observation methods could be quickly switched by changing the dark field and phase contrast slider. The phase contrast and bright field slider is universal for 4x-100x objectives, simple and fast to use. The aperture diaphragm of the condenser is easily set to get exact value of diaphragm to correspond with different objectives.



(5) LED EPI-Fluorescent Illumination. The LED EPI-Fluorescent Illumination is safe and convenient. There is no need to warm up or cool down, and also no need to align the bulb. The life time of LED bulb is up to 5000 hours. There are two filters position available and switch is fast and easy.



## 2. Infinite Plan Objectives.

The BS-2074 series microscopes have been fully optimized for various of microscopic applications, especially for beginners and the users with long time operation. The objectives provide high quality images and are easy to use.



- (1) Plan Objective. With infinite plan objective, clear and flat image is over the entire field of view, image reproduction is better.
- (2) 100× Water-immersion Objective. Ordinary 100× oil-immersion objective needs to use cedar oil as the observation medium. After use, it needs to be cleaned with ether alcohol or xylene, which is easy to cause air pollution and improper cleaning. The water-immersion objective uses water as the medium, it is easy to clean, it also reduces the damage to the user's health and environmental pollution.
- (3) 40× LWD Objective. The working distance of 40× objective can be up to 1.5mm, avoiding the contamination from residual immersion oil or water when converted from 100× to 40× objective.

### 3. This is an unbounded microscope.

Multifunctional digital head is optional, the user does not have to be confined in front of the microscope. Instead, it can be used for mobile microscope teaching and outdoor field observation through mobile terminals and external mobile power. The objective, eyepiece and observation tube have been effectively anti-mold treated, so it can ensure a consistently clear image and extend the life of the microscope, even when working in hot and humid environments.

(1) Multifunctional Digital Head. The built-in camera, supporting Android, IOS, Windows operating system, wired and Wifi modes. Images can be output to the external device in real time, there is no data cable connection, the operator can move more freely.



(2) Professional microscopic imaging software. Microscopic imaging observation, analysis and processing can be performed on external devices, including photographing, measurement, image adjustment, storage, synthesis, etc.

(3) Perform image preview and processing by scanning with Mobile devices. By scanning the QR code on the microscope, installing the APP and identifying the microscope, you can view the microscopic image on your phone and tablet.



(4) External rechargeable battery can be used as the power source. A USB charging port is reserved on the back of the microscope, external rechargeable portable battery can be connected to this port and used as power source of the microscope. So this microscope can be used outdoor or during power outages.



#### 4. Intelligent operating system.

##### (1) Coded Nosepiece.

The BS-2074 series microscope can memorize the illumination brightness when using each objective. When the objective has been changed, the light intensity will be automatically adjusted to reduce visual fatigue and improve work efficiency.



##### (2) Use a dimming knob to achieve multiple functions.

One Click: Enter standby status

Double Clicks: Light lock or unlock

Rotation: Adjust brightness

Press + Up-spin: Switch to the upper light source

Press + Down-spin: Switch to the under light source

Press 3 seconds: Set the time of turning off the light after leaving



##### (3) The display of microscope working status.

The LCD on the front of the microscope can display the working status of the microscope, including magnification, light intensity, sleepy model and so on.



Start & working mode



Lock mode



ECO mode



Sleep mode

#### 5. Easier to store and transport.

The microscope is compact and can be placed in an ordinary classroom closet. It has a special carrying handle, and it is also light weight and stable. There is a cord rest on back of the microscope to store the long power cord, improve the cleanliness of the laboratory and reduce the tripping accident which may be caused by the long power cord during the carrying process. The wooden storage box is optional, it is very convenient for storage and carrying.





### 6. Ergonomic Design.

In daily scientific research teaching and pathological diagnosis, working in front of the microscope for a long time has become normal, this always leads to fatigue and physical discomfort, thereby reducing work efficiency. BS-2074 series microscopes have adopted high eye-point, low-hand focus mechanism, low-hand stage and other ergonomic designs to ensure the user can perform microscope operation in the most comfortable situation. The focus knob, illumination control knob and stage handle are all proximal. The user can put both hands on the table while working, and can operate the microscope with minimal movement.



### Application

BS-2074 series microscopes are ideal instrument in biological, histological, pathological, bacteriology, immunizations and pharmacy field and can be widely used in medical and sanitary establishments, laboratories, institutes, academic laboratories, colleges and universities.

### Specification

Item	Specification	BS-2074B	BS-2074T
Optical System	Infinite Optical System	•	•
Eyepiece	Extra Wide Field Eyepiece EW10×/22mm	•	•
	Wide Field Eyepiece WF15×/16mm	○	○

	Wide Field Eyepiece WF20x/12mm	○	○
Viewing Head	Seidentopf Binocular Viewing Head, Inclined at 30°, 360° Rotatable, Interpupillary 47-78mm, Anti-Fungus, Tube Diameter 30mm	●	
	Seidentopf Trinocular Viewing Head, Inclined at 30°, 360° Rotatable, Interpupillary 47-78mm, Splitting ratio 5:5, Anti-Fungus, Tube Diameter 30mm		●
	Seidentopf Binocular Viewing Head with Built-in 5.0MP Digital Camera, HDMI and Wifi output interface, Inclined at 30°, 360° Rotatable, Interpupillary 47-78mm, Anti-Fungus, Tube Diameter 30mm	○	○
Objective	NIS60 Infinite Plan Achromatic Objective 4x (N.A.:0.10, W.D.:30mm)	●	●
	NIS60 Infinite Plan Achromatic Objective 10x (N.A.:0.25, W.D.:10.2mm)	●	●
	NIS60 Infinite Plan Achromatic Objective 40x (N.A.:0.65, W.D.:1.5mm)	●	●
	NIS60 Infinite Plan Achromatic Objective 100x (Water, N.A.:1.10, W.D.:0.2mm)	●	●
	NIS60 Infinite Plan Achromatic Objective 20x (N.A.:0.40, W.D.:4.0mm)	○	○
	NIS60 Infinite Plan Achromatic Objective 60x (N.A.:0.80, W.D.:0.3mm)	○	○
	NIS60 Infinite Plan Achromatic Objective 100x (Oil, N.A.:1.25, W.D.:0.3mm)	○	○
	NIS60 Infinite Plan Phase Contrast Achromatic Objective 10x, 20x, 40x, 100x	○	○
	NIS60 Infinite Plan Semi-APO Fluorescent Objectives 4x, 10x, 20x, 40x, 100x	○	○
Nosepiece	Backward Quintuple Nosepiece(Coding)	●	●
Stage	Rackless stage, Size 230x150mm, Moving Range 78x54mm	●	●
Condenser	Inserted Abbe Condenser NA1.25(Including Empty Plate)	●	●
	Bright Field-Phase Contrast Plate (4x-100x Universal)	○	○
	Bright Field-Dark Field Plate	○	○
Focusing	Coaxial coarse and fine adjustment, Coarse stroke 37.7mm per rotation, Fine stroke 0.2mm per rotation, Fine division 0.002mm, Moving range 30mm	●	●
Illumination	3W S-LED (LCD Display Magnification, Timing Sleep, Brightness Indication and Lock, etc.)	●	●
Fluorescent Attachment	3W LED, Two Filter Cubes (B, B1, G, U, V, R, Auramine O can be combined), Fly-eye Lens Illumination	○	○
Other Accessories	1x C-mount adapter	○	○
	0.5x C-mount adapter	○	○
	Simple Polarization Set	○	○
	Digital Camera	○	○
Filter	Green	●	●
	Blue, Yellow, Red	○	○
Package	1pc/carton, Carton size: 48cm*33cm*60cm, Net/Gross Weight: 10.5kg/12.5kg	●	●

Note: ●Standard Outfit, ○Optional

## System Diagram

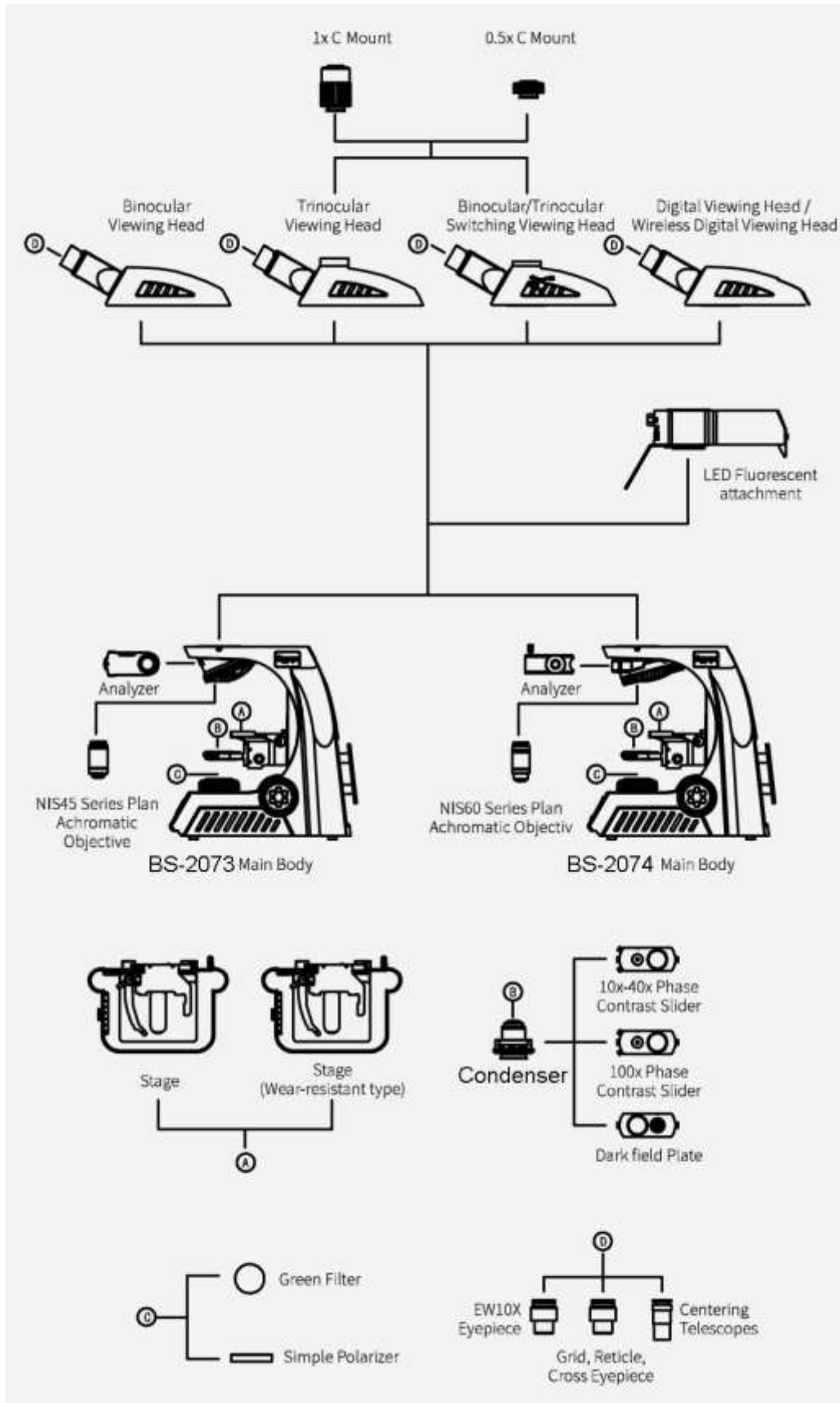

### Sample Image

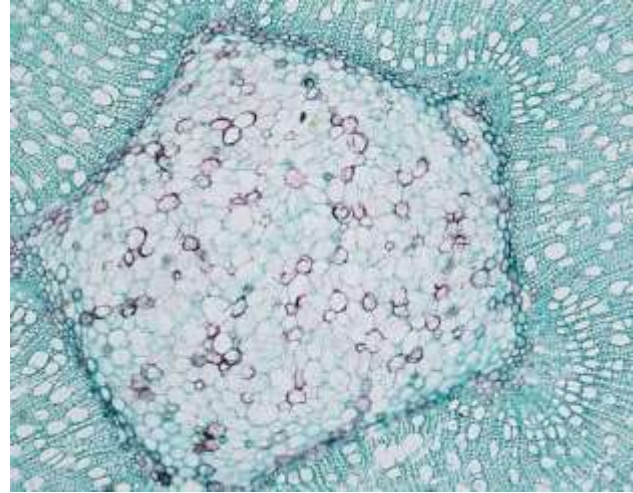
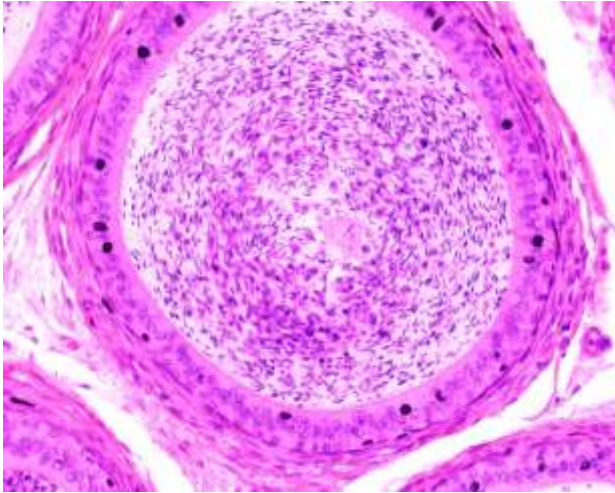

### Dimension

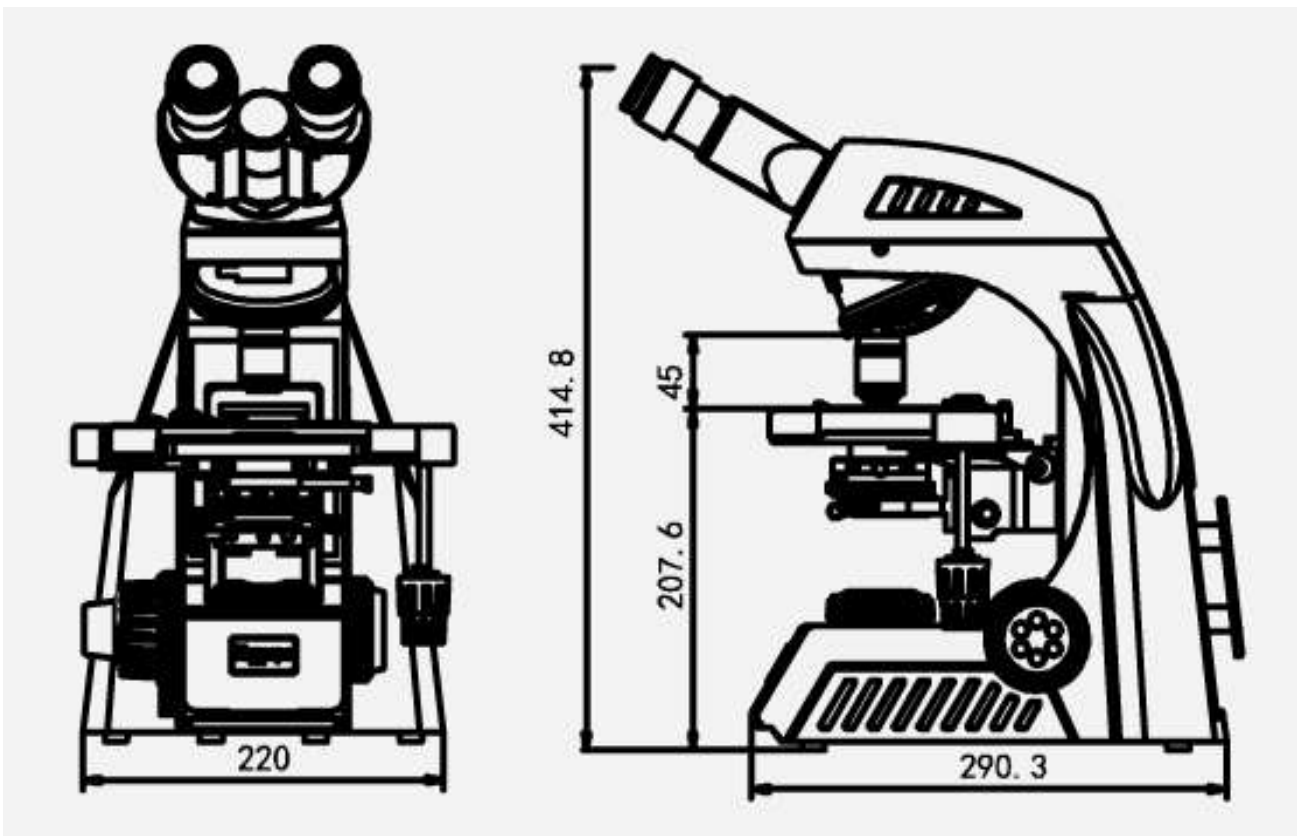

Unit:mm