

BALANCED-COIL NEEDLE DETECTOR

The newest range of needle detectors designed by YORK Technology Ltd. in UK, represent the next generation of digital instruments, to protect consumers from needle stick injury, ensuring product integrity, whilst enabling compliance validation to safeguard retailer brand reputation.



Model: ND-225

✦ KEY BENEFITS

- ✓ **High sensitivity 360° encircling coil**
- ✓ **ELIMINATE:**
 - Blind spots in corners and aperture edges
 - 9-point testing
 - Passing product twice, flipping or rotating
 - Constructing exclusion zones and 'quiet' rooms
 - Double head detection
- ✓ **Designed in the UK to comply with British Electromagnetic Compatibility (EMC) standard BS EN 6100-6-2 for immunity in industrial environments**
- ✓ **Large flash memory retains Advanced Due-Diligence data - downloaded via USB port**
- ✓ **International Retailer Approved!**

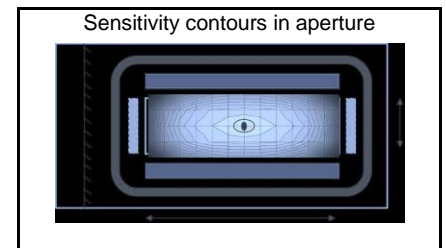

Designed and tested in the UK, using proven detector technology YORK Needle Detection systems offer a fully integrated inspection solution, ensuring clothing, footwear, soft toys, and other next-to-skin sewn products such as automotive and home textiles are free of potentially dangerous broken needle parts.



Winning dozens of international retailer approvals for the “YDS” brand, with installations in over 40 countries, YORK Technology today continues to build on its pioneering work of the last 14 years in the application of balanced-coil electro-magnetics to discovering solutions for effective metal detection in the textile industry.



Finding the right metal: ‘Phase-detection’ signal processing techniques enable machine software to distinguish between different types of metal. This means it is able to detect small fragments of broken needles whilst ignoring other metals including non-ferrous zippers, studs and accessories.



Approved metal trim

FEATURES

SOFTWARE

- Password protected against unauthorised access
- Preconfigured plug and play factory set up
- Automatic Product Learn for optimum non-ferrous metal setting
- Adjustable timed ‘Test Me’ alarm prompt assures calibration throughout
- On-screen Product and Reject Counts
- Advance Machine Diagnostic information displayed in real time for ease of servicing

- **Multiple languages:** English, French, German, Spanish, Czech, Greek, Dutch, Italian, Turkish, Traditional Chinese, Simplified Chinese, Korean, Indonesian, Thai

Main Display



Detection Event



Traditional Chinese



DATA LOGGING & DUE DILIGENCE REPORTING



Production Report

- Real Time Clock & Calendar for time stamped information
- One month Production Data Storage capacity in Flash Memory
- Due-Diligence Audit Trail
- Custom Batch Report headers according to product and buyer
- Unique method of Independent Compliance Verification
- Download Reports via USB link to PC

FEATURES (continued)

POWERFUL PROCESSING PLATFORM

- Dual Processor Control for accuracy, speed and more functionality
- 32bit ARM Cortex-M3 front-end host processor
- MicroChip16bit dsPIC Controller for dedicated needle detection signal processing with direct digital frequency synthesis, tuning, filtering, conversion, diagnostics and host communications
- 4.3 inch Colour LCD touch screen
- USB and Ethernet LAN capability
- Future proof enabling technology

FLEXIBLE CONVEYOR CONTROL



Belt Speed and Reversing Options

- Touch screen conveyor start-stop
- Adjustable belt speed - from 20 to 40 metres per minutes
- Software selectable Reject action:
 - Stop-on-Detect
 - Reverse-on-Detect
- Adjustable Stop-on-Detect distances
- Adjustable Reverse-on-Detect timing
- Actual belt speed feedback displayed in real time
- Reject alarm audio-visual indications

MECHANICAL

- Balanced Coil design *without* magnets for proven high sensitivity
- Solid encapsulated detector head, fully welded steel frame ensuring lifetime strength, durability and appearance
- Non-Magnetising AC field - saves having to de-magnetise conveyor parts, and preserves sensitivity performance
- Stainless steel rollers to ensure belt underside remains clean for longer
- Quick belt release mechanism for easy cleaning to minimise downtime
- Security key function to support QA protocols and positive release of goods under quarantine operation
- Convenient conveyor out-feed design to enable easy location in a through-wall product gateway, without compromising at-site serviceability
- Mechanical safety conveyor start interlock
- Emergency conveyor-stop button
- Maneuverable conveyor on lockable castor wheels for easy system location
- Lockable hinged control box lid for ease of service access
- Metal product guides and belt guards

TECHNICAL DATA

Overall dimensions in millimeters Model ND-225 shown:

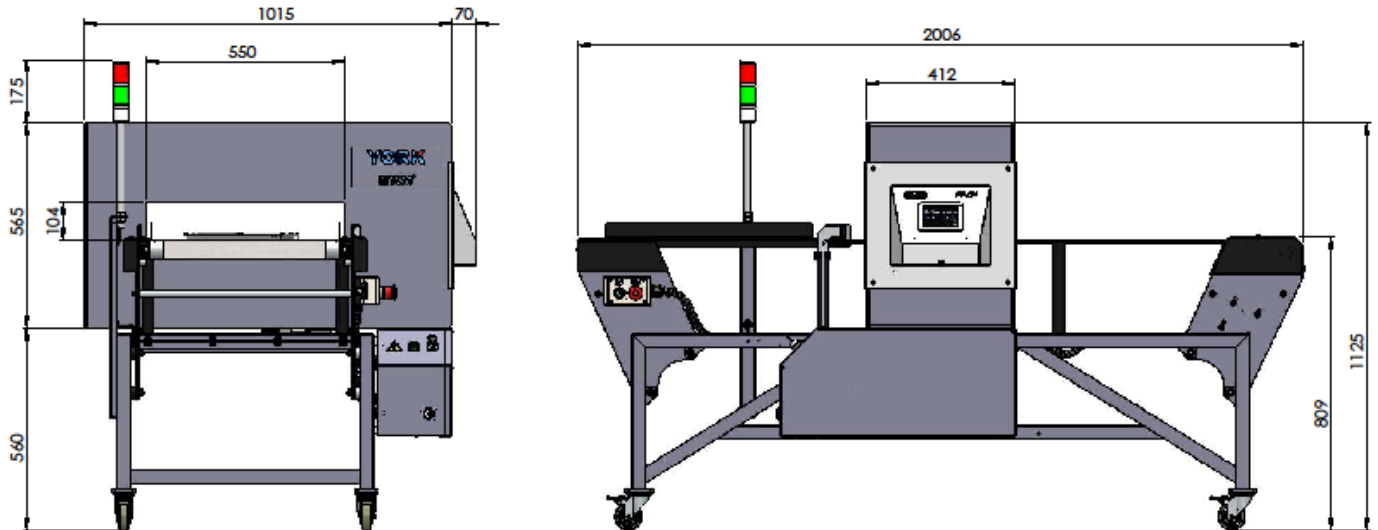

Models	Detection Aperture / Tunnel Size *				Sensitivity **	Mechanical Data	
	Width		Height		Ferrous Ball diameter mm	Overall Dimensions mm (approx.)	Weight Kg
	mm	inches	mm	inches			
ND-225	550	22	125	5	0.8 – 1.0	L 2006 x W 1085 x H 1128	357
ND-227	550	22	175	7	1.0 – 1.2	L 2006 x W 1085 x H 1208	tbc
ND-229	550	22	225	9	1.2 – 1.5	L 2006 x W 1085 x H 1258	tbc
ND-269	650	26	225	9	1.2 – 1.5	L 2006 x W 1205 x H 1258	tbc
ND-2611	650	26	275	11	1.5 – 1.8	L 2006 x W 1205 x H 1308	tbc
ND-2613	650	26	325	13	1.8 – 2.0	L 2006 x W 1230 x H 1385	tbc

*Allow approx 12mm (0.5 inch) minimum clearance all around the product for its clean passage through the tunnel on the conveyor belt.

** Detection Sensitivity measured in 'free space', at the weakest point inside the tunnel = Point 'A5' in GAP Calibration Chart.

NOTE 1: The sensitivity data is presented as a general guide, actual achievable sensitivity will depend on the contaminant and product size, type, packaging, orientation, location within the detection aperture and operating environment as well as any 'product effect'

SPECIFICATIONS	
Alarm Method	Stop-or-Reverse on detect – software selectable with adjustable distance / time
Alarm Type	Buzzer with selectable alarm tones, red colour light beacon on detection event
Belt Speed	Factory set 30 meters/minute – software adjustable from 20 to 40 meters/min
Production Throughput	30,000 typical items per 8-hour shift (average) @30 meters/min
<i>In accordance with EN 61010-1:2001, this equipment has been designed to be safe at least under the following conditions:</i>	
Conveyor load (max)	10kg
Operating Voltage	<i>Detector Head/Control Box:</i> Universal 85-260 V / 50-60 Hz Single Phase (Earthed) <i>Conveyor Motor:</i> 115 or 230V AC Single Phase – specified according to region
Current Consumption	Max 2 Amps
Storage Temperature	-10°C to +50°C (15°F to 122°F)
Operating Temperature	-5°C to +40°C (23°F to 104°F)
Relative Humidity (max)	93% for temperatures up to 45°C (113°F)
Pollution Degree	2 in accordance with IEC 664
NOTE 2: For reasons of electrical safety, electromagnetic interference and measurement accuracy, <u>this equipment must be earthed.</u>	

As part of a continuing process of development, the company reserves the right to alter specifications and other product details without notice